

SC Series Swing Check Valves

Submittal Data Sheet



< STANDARDS >



ASTM D1784

IPEX SC Swing Check Valves combine superior flow rate with maximum versatility. Stainless wetted parts and hardware, a top entry design, and integral flanged ends are just a few key features. With extremely low back pressure requirements, these valves are ideal for back-flow prevention in large diameter lines, both horizontal and vertical. SC Swing Check Valves are part of our complete systems of pipe, valves, and fittings, engineered and manufactured to our strict quality, performance, and dimensional standards.



ANSI B16.5

VALVE AVAILABILITY

Body Material	PVC
Size Range	3" – 8"
Pressure	100 psi (3") 70 psi (4" to 8")
Seals	EPDM, or Viton® (FPM)
End Connections	Flanged (ANSI 150)

SC Series Swing Check Valves

Submittal Data Sheet

Sample Specifications

1.0 Ball Valves – SC

1.1 Material

- The valve body, bonnet, swing arm, and disc shall be made of PVC compound which shall meet or exceed the requirements of cell classification 12454 according to ASTM D1784.

1.2 Seals

- The o-ring seals and shutter shall be made of EPDM.
or
- The o-ring seals and shutter shall be made of FPM.

1.3 Bolts

- The bolts, nuts, and washers shall be made of 304 stainless steel.

2.0 Connections

2.1 Flanged style

- The ANSI 150 flanged PVC end connections shall conform to the dimensional standard ANSI B16.5.

3.0 Design Features

- All swing check valves shall be full flow.
- All valves shall be gravity operated.
- The valve shall have a full face disc seal.
- The valve shall have a full open disc stop to prevent over-travel.
- The valve shall have no wetted metal parts.
- Service of the valve shall be possible without removal from the system line.
- All check valves may be installed in either horizontal or vertical orientations.

3.1 Pressure Rating

- Valve sizes 3" shall be rated at 100 psi at 73°F.
- Valve sizes 4" through 8" shall be rated at 70 psi at 73°F.

3.2 Markings

- All valves shall be marked to indicate size, material designation, and manufacturers name or trade mark.

3.3 Color Coding

- All PVC valves shall be color-coded dark gray.

- 4.0** All valves shall be Xirtec® PVC by IPEX or approved equal.

SC Series Swing Check Valves

Submittal Data Sheet

Valve Selection

Size (inches)	Body Material	O-ring Material	IPEX Part Number Flanged	Pressure Rating @ 73°F
3	PVC	EPDM	052289	100 psi
		Viton®	053875	
4	PVC	EPDM	052290	70 psi
		Viton®	053876	
6	PVC	EPDM	052291	70 psi
		Viton®	053877	
8	PVC	EPDM	052292	70 psi
		Viton®	053878	

Size (inches):

- 3 6
 4 8

Seals:

- EPDM
 Viton® (FPM)

IPEX Part Number:

Dimensions and Weights

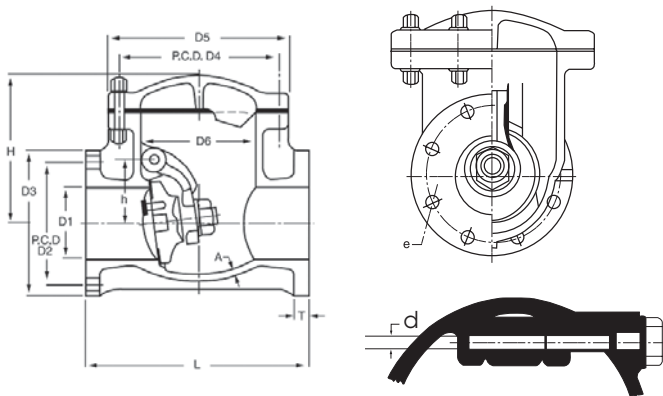

Dimension (inches)

Size	D1	D2	D3	D4	D5	D6	e	# holes
3	3.16	6.00	7.50	7.13	8.06	5.13	0.75	4
4	3.94	7.50	9.00	9.25	10.44	6.69	0.75	8
6	5.53	9.50	11.00	13.00	14.56	9.84	0.88	8
8	7.88	11.75	13.50	15.31	16.71	11.81	0.88	8

Dimension (inches)

Size	L	T	A	h	H	d	W (lbs)
3	10.25	0.79	0.34	2.75	6.72	0.47	8.25
4	11.82	0.90	0.41	3.53	8.38	0.63	19.40
6	15.75	1.20	0.63	5.31	10.56	0.78	28.66
8	16.69	1.22	0.72	6.69	12.06	0.78	46.30

Pressure – Temperature Ratings

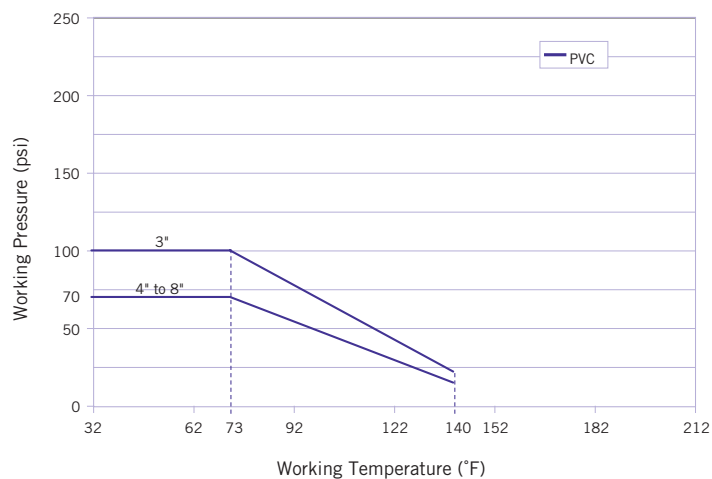

Minimum Back Pressure to Seal

Size	PSI
3	8.5
4	9.7
5	9.7
6	11.9
8	11.9

SC Series Swing Check Valves

Submittal Data Sheet

Installation Procedures

1. Ensure that the valve is in the correct orientation then carefully place the valve in the system between the two pipe flanges.
2. Join each end of the valve to the pipe flanges. For correct joining procedure, please refer to the section entitled, "Joining Methods – Flanging" in the IPEX Industrial Technical Manual Series, "Volume I: Vinyl Process Piping Systems".



Disassembly

1. If removing the valve from an operating system, isolate the valve from the rest of the system. **Be sure to depressurize and drain the isolated branch and valve before continuing.**
2. Loosen end of the valve from the pipe flanges. Please refer to the section entitled, "Joining Methods – Flanging" in the IPEX Industrial Technical Manual Series, "Volume I: Vinyl Process Piping Systems" for a recommended bolt tightening pattern diagram. Follow the same pattern when disassembling the flanged joints.
3. Carefully remove the valve from the line.
4. Loosen and remove the nuts (10), bolts (11), and washers (12) then remove the bonnet (2) and gasket (7) from the top of the valve body (1).
5. Loosen the shaft holder (14) and remove the o-ring (13).
6. Remove the shaft (8) then take the swing arm (5) assembly out of the valve.
7. To disassemble the swing arm, loosen the set bolt(s) (15) then remove the gasket holder (4) and disc gasket (6) from the disc (3).
8. The valve components can now be checked for problems and/or replaced.

Note: The disc and disc holder (9) are permanently fixed to the swing arm by the set pin (16) and cannot be disassembled.

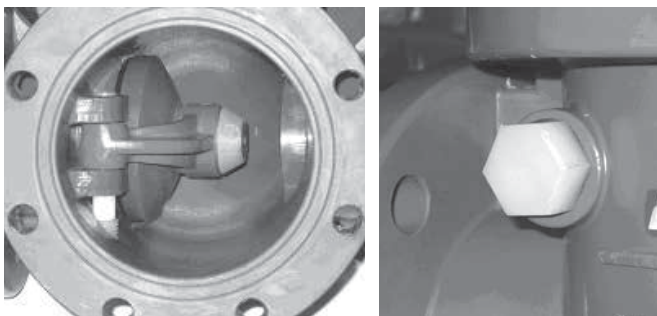

Assembly

Note: Before assembling the valve components, it is advisable to lubricate the o-rings with a water soluble lubricant. **Be sure to consult the "IPEX Chemical Resistance Guide" and/or other trusted resources to determine specific lubricant-rubber compatibilities.**

1. Assemble the swing arm (5) components by placing the disc gasket (6) and gasket holder (4) on the disc (3) then tightening the set bolt(s) (15).
2. Place the swing arm assembly into the valve body (1) then insert the shaft (8) through the mounting holes.
3. Fit the o-ring (13) on the shaft holder (14) then sufficiently tighten into the valve body.
4. Taking care to line up all the holes, place the gasket (7) and bonnet (2) onto the valve body.
5. Insert and tighten all nuts (10), bolts (11), and washers (12) according to a proper flange bolt tightening pattern.



Testing and Operating

The purpose of system testing is to assess the quality of all joints and fittings to ensure that they will withstand the design working pressure, plus a safety margin, without loss of pressure or fluid. Typically, the system will be tested and assessed in sub-sections as this allows for improved isolation and remediation of potential problems. With this in mind, the testing of a specific installed valve is achieved while carrying out a test of the overall system.

An onsite pressure test procedure is outlined in the IPEX Industrial Technical Manual Series, "Volume I: Vinyl Process Piping Systems" under the section entitled, "Testing". The use of this procedure should be sufficient to assess the quality of a valve installation. **In any test or operating condition, it is important to never exceed the pressure rating of the lowest rated appurtenance in the system.**

Important points:

- Never test thermoplastic piping systems with compressed air or other gases including air-over-water boosters.
- When testing, do not exceed the rated maximum operating pressure of the valve.
- Avoid the rapid closure of valves to eliminate the possibility of water hammer which may cause damage to the pipeline or the valve.

Please contact IPEX customer service and technical support with regard to any concern not addressed in this data sheet or the technical manual.

About the IPEX Group of Companies

As leading suppliers of thermoplastic piping systems, the IPEX Group of Companies provides our customers with some of the world's largest and most comprehensive product lines. All IPEX products are backed by more than 50 years of experience. With state-of-the-art manufacturing facilities and distribution centers across North America, we have established a reputation for product innovation, quality, end-user focus and performance.

Markets served by IPEX group products are:

- Electrical systems
- Telecommunications and utility piping systems
- Industrial process piping systems
- Municipal pressure and gravity piping systems
- Plumbing and mechanical piping systems
- Electrofusion systems for gas and water
- Industrial, plumbing and electrical cements
- Irrigation systems
- PVC, CPVC, PP, PVDF, PE, ABS, and PEX pipe and fittings

This literature is published in good faith and is believed to be reliable. However, it does not represent and/or warrant in any manner the information and suggestions contained in this brochure. Data presented is the result of laboratory tests and field experience.

A policy of ongoing product improvement is maintained. This may result in modifications of features and/or specifications without notice.