

# S12/22 Series Solenoid Valves

## Product Data Sheet



### < STANDARDS >



ASTM D1784  
ASTM D2464  
ASTM D2466  
ASTM D2467  
ASTM F1498



ANSI B1.20.1

The IPEX S12/22 Series True Union Solenoid Valves represent the latest innovation in valve manufacturing technology. The S12/22 Series replaces the well-received SF Series with a number of new features and is designed for industrial, OEM and water service applications. The S12/22 is direct acting, 2 way-2 position flow control valve, ideal for precise control and high-cycle service. The new high-performance electric solenoid actuator has been redesigned to exceed 5 million cycles without having to perform maintenance and a 100% duty cycle means no issues with overheating or "burnout". With their lever type shutter design, standard manual override, and LED position indicator, these valves will outlast and outperform more conventional diaphragm-style solenoid valves.

S12/22 Solenoid Valves are part of our complete system of IPEX pipe, valves and fittings, engineered and manufactured to our strict quality, performance and dimensional standards.

### VALVE AVAILABILITY

<b>Body Material</b>	PVC
<b>Size Range</b>	1/4" through 1/2"
<b>Pressure</b>	up to 90 psi
<b>Seals</b>	EPDM or FPM
<b>End Connections</b>	Socket (IPS), Threaded (FNPT)

# S12/22 Series Solenoid Valves

## Product Data Sheet

### Sample Specification

#### 1.0 Solenoid Valves – S12/22

##### 1.1 Material

- The valve body, end connectors, and unions shall be made of PVC compound which shall meet or exceed the requirements of cell classification 12454 according to ASTM D1784.

##### 1.2 Seals

- The o-ring seals and shutter shall be made of EPDM.
- or The o-ring seals and shutter shall be made of FPM.

#### 2.0 Connections

##### 2.1 Socket style

- The IPS socket PVC end connectors shall conform to the dimensional standards ASTM D2466 and ASTM D2467.

##### 2.2 Threaded style

- The female NPT threaded PVC end connectors shall conform to the dimensional standards ASTM D2464, ASTM F1498, and ANSI B1.20.1.

#### 3.0 Design Features

- The valve shall have true union ends.
- The valve opening and closing mechanism shall be a lever type shutter.
- The valve shall have a standard LED indicator.
- The valve shall have an integrated manual override in the event of a loss of power to the valve.
- The electric solenoid actuator shall be designed to exceed 5 million cycles without having to perform maintenance.
- All metallic valve parts shall be isolated from fluids and the external environment.
- All screws shall be protected by polyethylene caps.

#### 3.1 Pressure Rating

- Valve sizes ND 0.16" (1/4) and ND 0.31" (1/2) shall be rated at 90 psi at 73°F.
- Valve sizes ND 0.24" (1/4) and ND 0.39" (1/2) shall be rated at 60 psi at 73°F.
- Valve sizes ND 0.31" (1/4) and ND 0.59" (1/2) shall be rated at 30 psi at 73°F.

#### 3.2 Markings

- All valves shall be marked to indicate size, material designation, and manufacturers name or trade mark.

#### 3.3 Color Coding

- All PVC valves shall be color-coded dark gray.
- 4.0 All valves shall be Xirtec® PVC by IPEX or approved equal.

# S12/22 Series Solenoid Valves

## Product Data Sheet

### Valve Selection

Size (inches)	Body Material	O-ring Material	IPEX Part Number		Pressure Rating	
			IPS Socket	FNPT Threaded		
1/4	0.16	PVC	EPDM	353687	353723	90 psi
			FPM	353711	353699	
1/4	0.24	PVC	EPDM	353688	353724	60 psi
			FPM	353712	353698	
1/4	0.31	PVC	EPDM	353689	353725	30 psi
			FPM	353713	353697	
1/2	0.31	PVC	EPDM	353696	353734	90 psi
			FPM	353722	353708	
1/2	0.39	PVC	EPDM	353709	353733	60 psi
			FPM	353721	353707	
1/2	0.59	PVC	EPDM	353710	353732	30 psi
			FPM	353720	353706	

### Size (inches):

- 1/4" – ND 0.16"
- 1/4" – ND 0.24"
- 1/4" – ND 0.31"
- 1/2" – ND 0.31"
- 1/2" – ND 0.39"
- 1/2" – ND 0.59"

### Seals:

- EPDM
- FPM

### IPEX Part Number:

-----

### Dimension and Weights

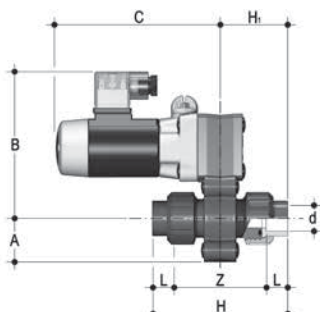

#### IPS socket connections – Dimension (inches)

Type	Size	d	ND	A	B	C	E	H	H1	L	M	Z	Weight (lbs)
S12	1/4	0.54	0.16	0.94	3.94	4.06	1.65	3.62	1.81	0.63	2.05	2.36	0.88
S12	1/4	0.54	0.24	0.94	3.94	4.06	1.65	3.62	1.81	0.63	2.05	2.36	0.88
S12	1/4	0.54	0.31	0.94	3.94	4.06	1.65	3.62	1.81	0.63	2.05	2.36	0.88
S22	1/2	0.84	0.31	1.34	4.53	5.12	2.13	4.57	2.28	0.87	2.64	2.80	2.20
S22	1/2	0.84	0.39	1.34	4.53	5.12	2.13	4.57	2.28	0.87	2.64	2.80	2.20
S22	1/2	0.84	0.59	1.34	4.53	5.12	2.13	4.57	2.28	0.87	2.64	2.80	2.20

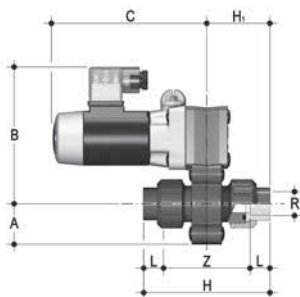

#### Female NPT threaded connections – Dimension (inches)

Type	Size	R	ND	A	B	C	E	H	H1	L	M	Z	Weight (lbs)
S12	1/4	1/4-NPT	0.16	0.94	3.94	4.06	1.65	3.58	1.77	0.59	2.05	2.40	0.88
S12	1/4	1/4-NPT	0.24	0.94	3.94	4.06	1.65	3.58	1.77	0.59	2.05	2.40	0.88
S12	1/4	1/4-NPT	0.31	0.94	3.94	4.06	1.65	3.58	1.77	0.59	2.05	2.40	0.88
S22	1/2	1/2-NPT	0.31	1.34	4.53	5.12	2.13	4.41	2.20	0.81	2.64	2.80	2.20
S22	1/2	1/2-NPT	0.39	1.34	4.53	5.12	2.13	4.41	2.20	0.81	2.64	2.80	2.20
S22	1/2	1/2-NPT	0.59	1.34	4.53	5.12	2.13	4.41	2.20	0.81	2.64	2.80	2.20

# S12/22 Series Solenoid Valves

## Product Data Sheet

### Pressure & Temperature Ratings

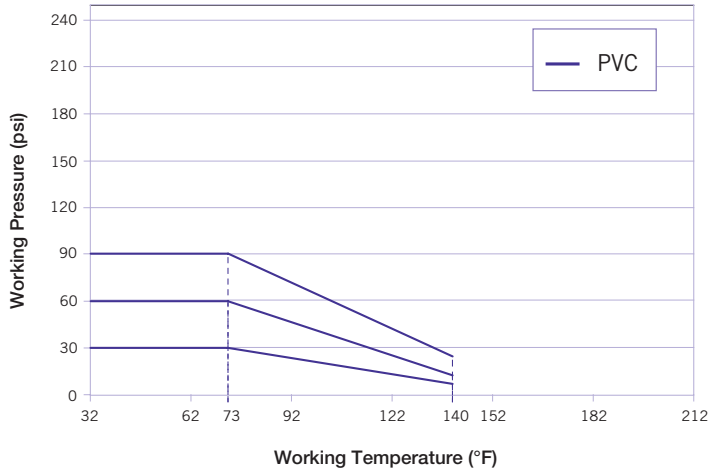

**Note:** The maximum ambient temperature allowed for the solenoid is 122°F (50°C).

### Electrical Data

Duty Cycle	100% ED
Closing Time	~ 20 ms
Opening Time	~ 20 ms
AC Voltage	110 V
Frequency	50/60 Hz
Voltage Allowances	± 10%
Power Consumption, S12	10W
Power Consumption, S22	20W
Protection Class	IP65
Electrical Connection	DIN 43650 connector with LED (1)

### Flow Coefficients

Size	ND	CV
1/4	0.16	0.46
1/4	0.24	0.84
1/4	0.31	1.06
1/2	0.31	1.91
1/2	0.34	2.37
1/2	0.59	4.04

### Pressure Loss Chart

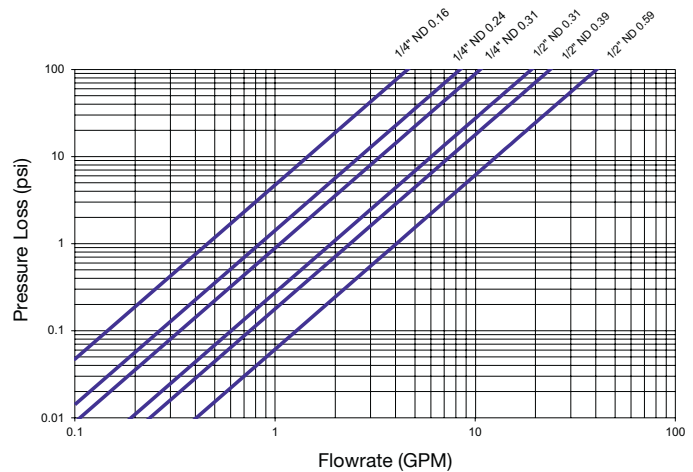

# S12/22 Series Solenoid Valves

## Product Data Sheet

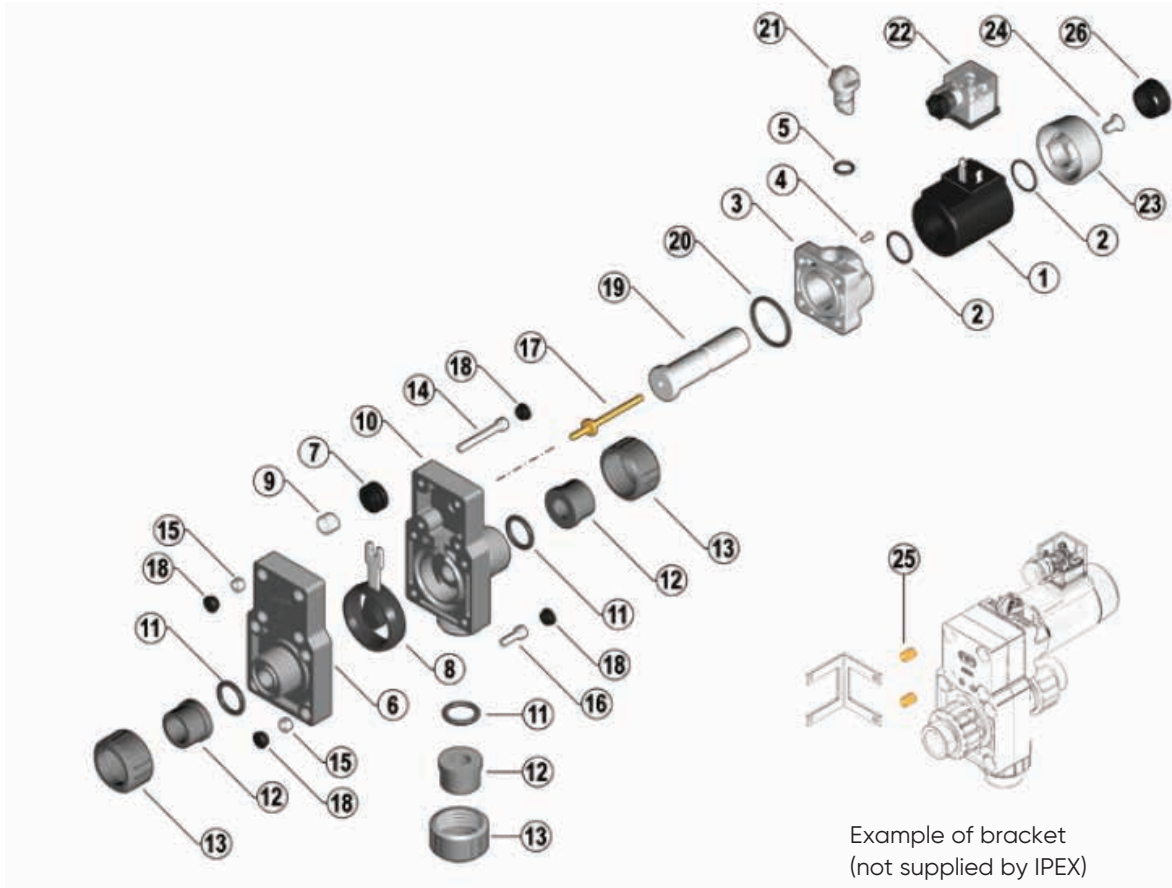

#	Component	Material	Qty
1	Coil	PA-GR	1
2	O-ring	EPDM	2
3	Housing for manual override	PP-GR	1
4	Screw	SS	1
5	O-ring	EPDM	1
6	Upper body	PVC	1
7	Spring slide	PP-GR	1
8	Shutter	EPDM or FPM	1
9	Return spring	SS	1
10	Lower body	PVC	1
11	O-ring	EPDM or FPM	2
12	End connector	PVC	2
13	Union nut	PVC	2
14	Screw	Zinc plated steel	4

#	Component	Material	Qty
15	Nuts	Zinc plated steel	8
16	Screw	Zinc plated steel	4
17	Control Spindle	Brass	1
18	Protection caps	PE	8
19	Operator	SS	1
20	O-ring	EPDM	1
21	Manual override	PP-GR	1
22	Connector	-	1
23	Coil cap	PPP-GR	1
24	Screw	SS	1
25	Bracketing nuts	Brass	2
26	Protection cap	PE	1

# S12/22 Series Solenoid Valves

## Product Data Sheet

### Installation Procedures

1. Remove the union nuts (part #13 on previous page) and slide them onto the pipe ends.
2. Solvent cement or thread the end connectors (12) onto the pipe ends. For correct joining procedures, please refer to the sections entitled, "Joining Methods – Solvent Cement" and "Joining Methods – Threading" in the IPEX Industrial Technical Manual Series, "Volume I: Vinyl Process Piping Systems".
3. Ensure that the desired direction of pipe flow matches the indicated direction on the valve and that the socket o-rings (11) are properly fitted in their grooves. Carefully place the valve in the system between the two end connections.
4. Tighten both union nuts. Hand tightening is typically sufficient to maintain a seal for the maximum working pressure. Over-tightening may damage the threads on the valve body and/or the union nut, and may even cause the union nut to crack.
5. Remove the connector (22) from the solenoid coil (1), disassemble, and then connect the electrical leads.
6. Reassemble the connector and reattach to the solenoid coil.

**Note:** It is advisable to support the valve with a mounting bracket as the weight of the solenoid may cause the pipeline to sag.



Where,

$f$  is the pressure drop (friction loss) in psi,

$sg$  is the specific gravity of the fluid,

$Q$  is the flow rate in GPM,

$C_v$  is the flow coefficient.

# S12/22 Series Solenoid Valves

## Product Data Sheet

### Disassembly

1. If removing the valve from an operating system, isolate the valve from the rest of the system. **Be sure to depressurize and drain the isolated branch and valve before continuing.**
2. Remove the connector (22) from the solenoid coil and detach the electrical leads. **Be sure to shut off the electrical source before detaching the leads.**
3. Loosen both union nuts (13) and drop the valve out of the line. If retaining the socket o-rings (11), take care that they are not lost when removing the valve from the line.
4. Remove the protection cap (26), unscrew the screw of the coil (24) and remove the cover of the coil (23).
5. Remove the coil (1) and the O-ring (2).
6. Remove the protective caps (18) and unscrew the screws (14).
7. Separate the actuator group from the valve body, remove the control spindle (17) and the O-ring (20).
8. Unscrew the screw (4) and remove the manual override (21) and the O-ring (5). Remove the operator (19) from the housing of the manual override (3).
9. Unscrew the screws (16) and separate the two half bodies (6 -10) and remove the shutter (8).
10. Remove the spring (9) from the spring slide (7) and then detach the spring slide from the shutter (8).

### Assembly

**Note:** Before assembling the valve components, it is advisable to lubricate the o-rings with a water soluble lubricant. **Be sure to consult the "IPEX Chemical Resistance Guide" and/or other trusted resources to determine specific lubricant-rubber compatibilities.**

1. Insert the spring slide (7) on the shutter rod (8) and the spring (9) onto the spring slide housing (7).
2. Put the shutter (8) on the upper body (6) taking care that the spring (9) is properly positioned into its groove.
3. Assemble the two half-bodies (6-10) tightening the screws (16) observing a cross pattern and the torque values suggested on the instruction sheet.
4. Insert the operator (19) into the housing for the manual override (3) up to the stop.
5. Place the O-ring (5) on the manual override (21) and tighten the screw (4). Verify that the manual override is free to rotate. Set it in "close" position.
6. Insert the control spindle (17) into the hole of the operator (19), place the o-ring (20) on the housing of the manual override groove.
7. Reassemble the actuator group on the valve body by tightening the screws (14) observing a cross pattern and the torque values suggested on the instruction sheet.
8. Insert all protective caps (18), place the coil (1), the coil cap (23) and fix it by tightening the screw (24). Refer to the maximum torque recommendation on the instruction sheet. Replace the protection cap (26).
9. Ensure that the socket o-rings (11) are properly fitted in their grooves then attach the end connectors (12) and union nuts (13).

# S12/22 Series Solenoid Valves

## Product Data Sheet

### Testing and Operating

The purpose of system testing is to assess the quality of all joints and fittings to ensure that they will withstand the design working pressure, plus a safety margin, without loss of pressure or fluid. Typically, the system will be tested and assessed in sub-sections as this allows for improved isolation and remediation of potential problems. With this in mind, the testing of a specific installed valve is achieved while carrying out a test of the overall system.

An onsite pressure test procedure is outlined in the IPEX Industrial Technical Manual Series, "Volume I: Vinyl Process Piping Systems" under the section entitled, "Testing". The use of this procedure should be sufficient to assess the quality of a valve installation. In any test or operating condition, **it is important to never exceed the pressure rating of the lowest rated appurtenance in the system.**

#### Important points:

- Never test thermoplastic piping systems with compressed air or other gases including air-over-water boosters.
- When testing, do not exceed the rated maximum operating pressure of the valve.
- Avoid the rapid closure of valves to eliminate the possibility of water hammer which may cause damage to the pipeline or the valve.

Please contact IPEX customer service and technical support with regard to any concern not addressed in this data sheet or the technical manual.



### About the IPEX Group of Companies

As leading suppliers of thermoplastic piping systems, the IPEX Group of Companies provides our customers with some of the world's largest and most comprehensive product lines. All IPEX products are backed by more than 50 years of experience. With state-of-the-art manufacturing facilities and distribution centers across North America, we have established a reputation for product innovation, quality, end-user focus and performance.

Markets served by IPEX group products are:

- Electrical systems
- Telecommunications and utility piping systems
- Industrial process piping systems
- Municipal pressure and gravity piping systems
- Plumbing and mechanical piping systems
- Electrofusion systems for gas and water
- Industrial, plumbing and electrical cements
- Irrigation systems
- PVC, CPVC, PP, PVDF, PE, ABS, and PEX pipe and fittings

Xirtec® is a registered trademark used under license.

This literature is published in good faith and is believed to be reliable. However, it does not represent and/or warrant in any manner the information and suggestions contained in this brochure. Data presented is the result of laboratory tests and field experience.

A policy of ongoing product improvement is maintained. This may result in modifications of features and/or specifications without notice.