



Labkotec GA-2 Monitoring System 40100MS Installation

These installation instructions are intended to supplement the Labkotec GA-2 Installation and Operating Instructions, as supplied by Labkotec with the monitor purchase.

This Instruction sheet covers the installation of the high water level / blockage sensor GA-HLL1 and the grease capacity sensor GA-SG1 into the Endura® XL grease interceptor. Follow supplied manufacturers instructions to complete remaining installation of monitoring unit through a qualified electrician.

The Labkotec GA-2 meets the requirements of the Miami-Dade DERM 2.0 Ordinance for applications requiring monitoring solutions.

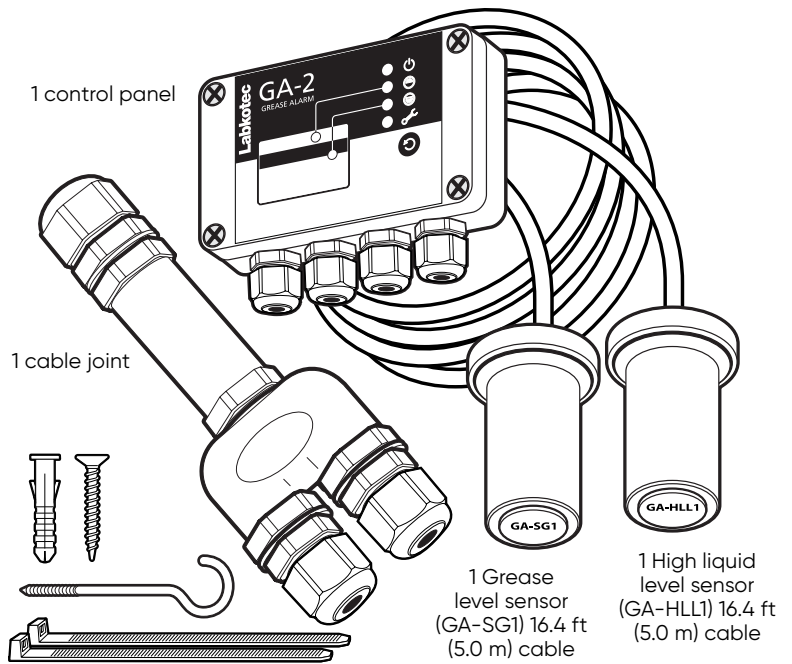

Installation accessories
Drywall plugs and screws and zip ties

Recommended (not included):
4 x AWG 20-16 unshielded cable (unshielded 4 x 0.5mm² or 0.75mm² or 1.5mm²) – length dependent on installation.
1 x thick-wall through wall tank wall adapter conduit - length dependent on installation.

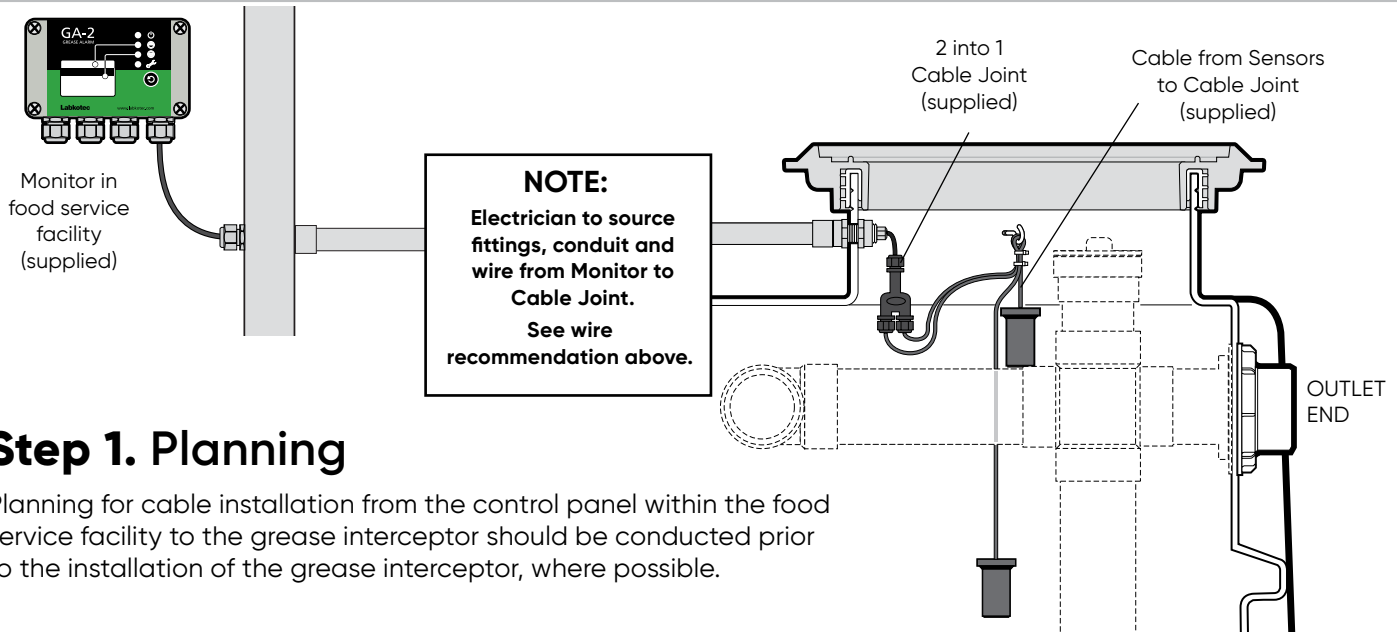

Step 1. Planning

Planning for cable installation from the control panel within the food service facility to the grease interceptor should be conducted prior to the installation of the grease interceptor, where possible.

Step 2. Location

It is recommended that the sensors be installed in the neck of the outlet side of the interceptor. Remove lid and depending on model purchased locate area free of internal piping obstructions (↑).

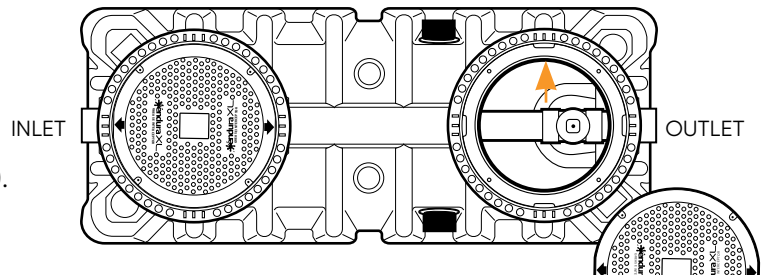

Technical Support
tech-support@endurainterceptor.com

Endura® is a registered trademark

Canada
Tel: (705) 726-3361
1-800-461-1771
Fax: (705) 726-2186

U.S.A.
Tel: (303) 373-1918
1-888-461-5307
Fax: (303) 373-1923

Step 3. Hook location: Installation

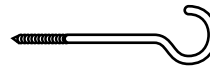

Drill a small pilot hole 1" under the edge of the cover frame to accept the C Hook screw provided to hang the sensors from (A), ensure no piping exists directly below this location. Install hook screw as shown below.

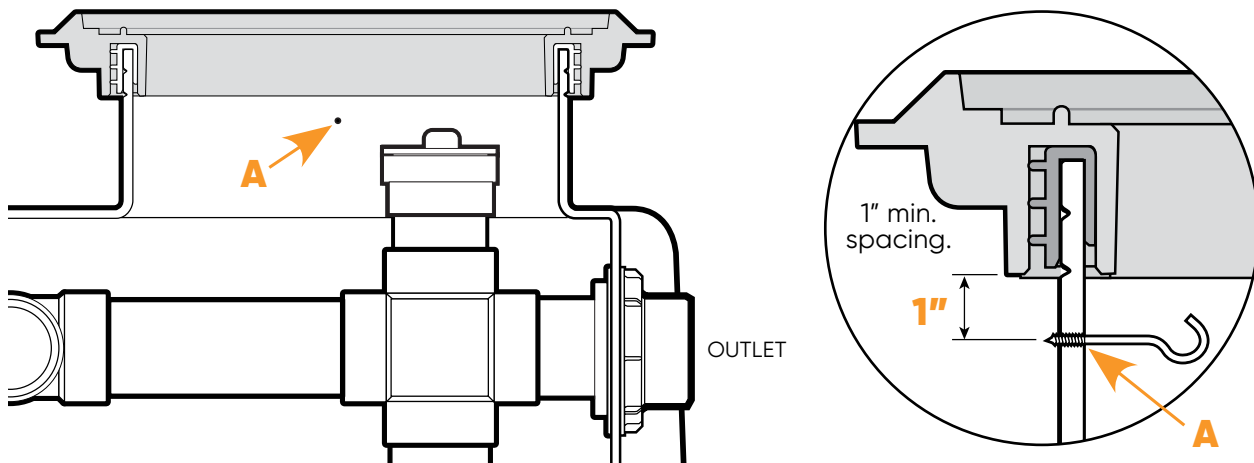

Step 4. Conduit installation

Electrical conduit connection can be made into the neck of the tank close to the bottom of the cover frame edge (approx. 1.5 in. below), above the working area of the interceptor. Fittings, conduit and cable wire from the monitor control panel to the tank is not supplied and should be sourced separately.

NOTE: Ensure fittings selected prevent sewer gases or water from entering conduit line.

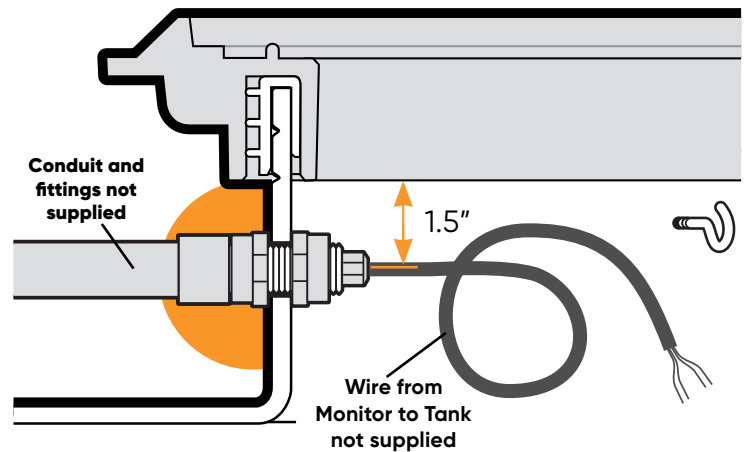

Step 5. Cable Joint

Connect Cable Joint to the inbound wire as shown in manufacturers manual diagram.

Leave enough length of wire to be able to lift cable joint outside of manhole for making installation connections and future maintenance (B).

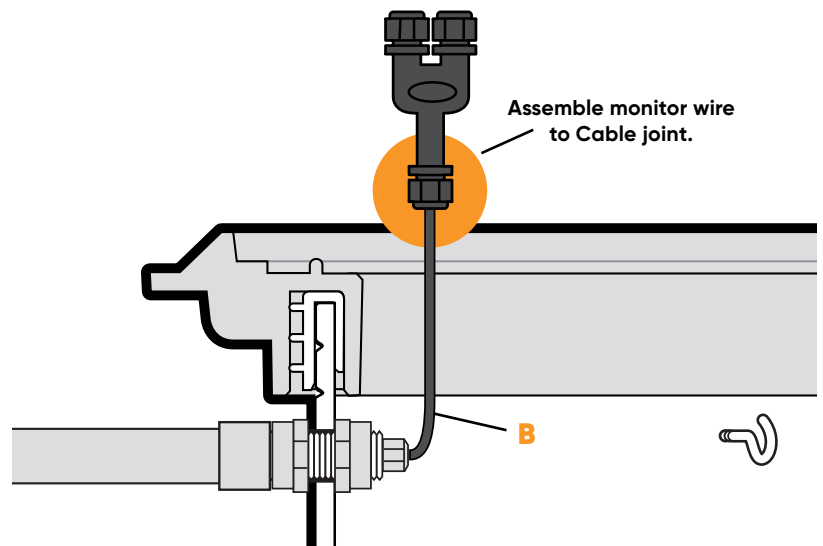

Step 6. Sensor positioning

1. Loop sensor cables over hook and hang below.
2. The **GA-HLL1 Blockage / high water Sensor** should hang from the hook so that the bottom of the sensor is level with the top of the outlet pipe, see figure below.

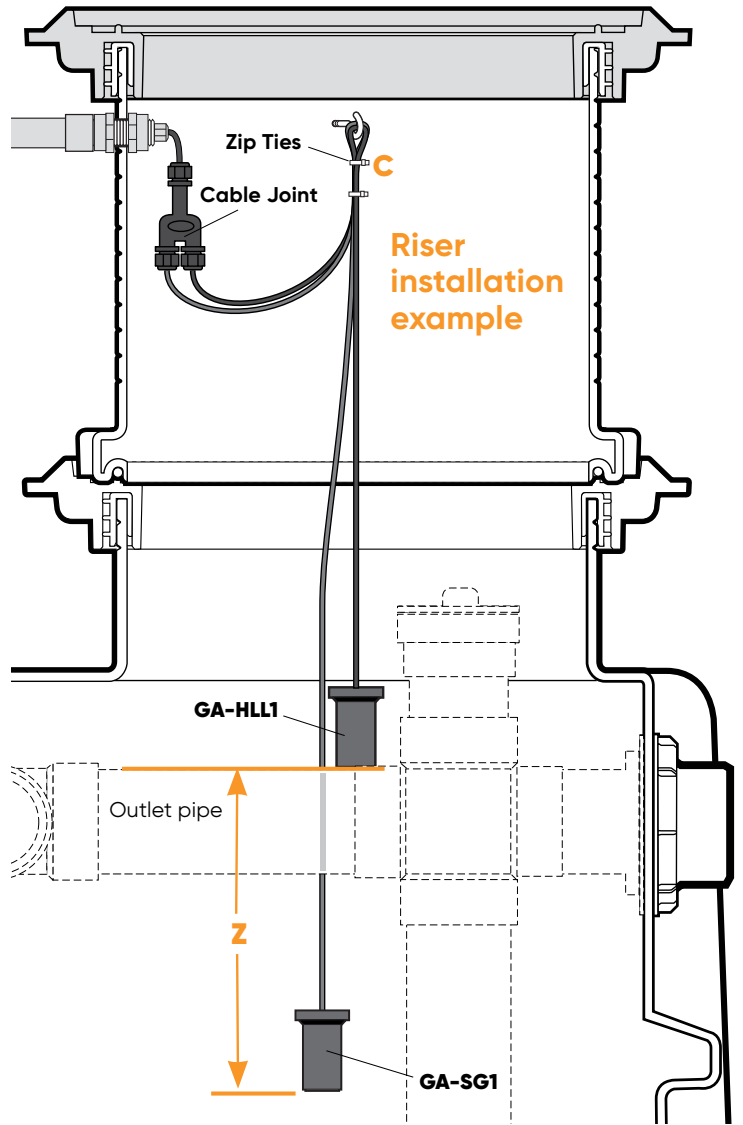
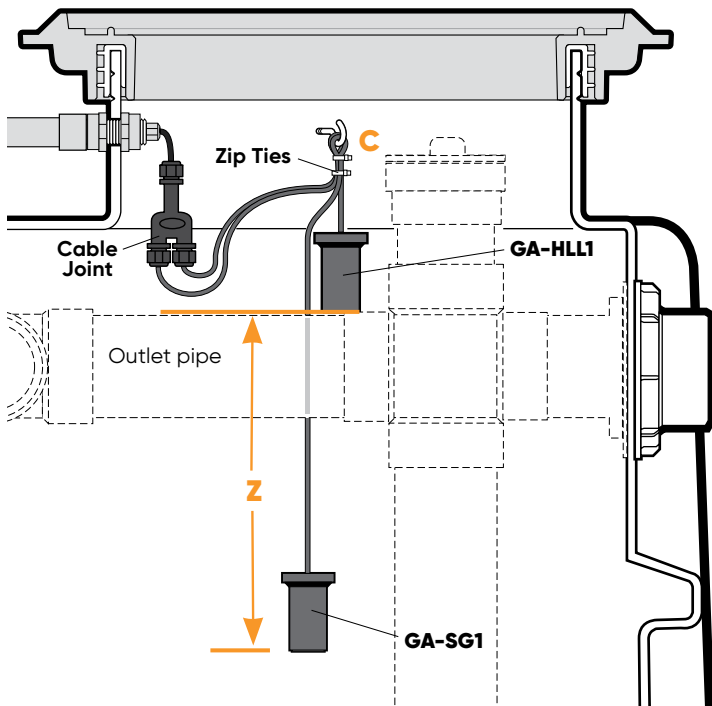

3. The **GA-SG1 Grease Capacity Alarm** should hang from the hook so that the bottom of the sensor is "**Z**" inches below the top of the outlet pipe, see chart below for the value of "**Z**" dimension depending on model purchased.
4. Once both sensors in position, use the **two zip ties** provided to secure the sensor cables together and form a loop as shown (**C**).

5. Attach sensor cables to Cable Joint as described in manufacturers manual.

Note: Excess length of sensor cable may be secured in a loop inside the tank or cut to length. Ensure enough cable length is provided so that the sensors may be lifted out of the interceptor during service and maintenance.

	Grease Capacity at Break down (lbs)	Endura Model	Flow Control Location	Grease Layer (in)	Z Dimension from top of outlet pipe (in)	
					For alarm signal at 50% Capacity	For alarm signal at 80% Capacity
Z Dimensions for Standard Installation (ASME A112.14.3)	715.3	XL50HE	External	15.7	11.8 in.	16.5 in.
	1243.8	XL75HE	External	20.4	14.2 in.	20.3 in.
	558.5	XL75	External	12.3	10.1 in.	13.8 in.
	1058.3	XL100	External	17.5	12.8 in.	18.0 in.
	1097.0	XL150	Internal	18.0	13.0 in.	18.4 in.
Z Dimensions for Miami Dade DERM 2.0 Compliant (99% Efficiency Installations)	108.9	XL50HE	External	2.5	5.2 in.	6.0 in.
	193.0	XL75HE	External	4.4	6.2 in.	7.5 in.
	1098.8	XL75 2*series	External	12.5	10.3 in.	14.0 in.
	2197.5	XL75 4*series	External	12.5	10.3 in.	14.0 in.
	1487.0	XL100 2*series	Internal	17.5	12.8 in.	18.0 in.
	2973.9	XL100 4*series	Internal	17.5	12.8 in.	18.0 in.

Step 7. Complete wiring to monitor box

Complete wiring to monitor box as instructed through Labkotec's manufacturers instructions.

Maintenance Notice:

It is important to ensure all personnel performing maintenance on the grease interceptor are aware of the monitor installation.

During grease interceptor cleaning, the sensors must be lifted out of the unit and placed safely aside.

Sensors must be wiped clean before being placed back inside the interceptor following service.

Ensure maintenance personnel has reviewed the Labkotec manufacturers installation instructions for information on handling the sensors during maintenance.

WARNING – SAFETY FIRST!

GREASE INTERCEPTORS ARE HAZARDOUS ENVIRONMENTS AND MUST NEVER BE LEFT UNCOVERED AND UNATTENDED, EVEN DURING MAINTENANCE.

- All access covers MUST be fully and completely secured
- All required bolts MUST at all times be in place and well tightened
- Missing bolts MUST be reported to management and replaced immediately
- Covers MUST meet the required load rating for the application (see the Technical Information section)
- Do NOT use alternate covers



Notes:
